

## NFC-FP-S04

KIT CONTROLE POUR TELEPHONE PORTABLE CONTROLE D'EMPREINTES DIGITALES CARTE  
IC MODULE RELAIS BRICOLAGE CONTROLE D ACCES CONTROLEUR DE CARTE COURTE.  
13.56MHZ



### Product descriptions from the supplier

#### Overview

Smartphone NFC fingerprint relay control panel IC 13.56mhz two-channel relay module car electric bicycle modification accessories

#### Product parameters:

Input voltage: DC10V-DC120V

Read card type: 13.56mhz

Unlocking method: IC card, fingerprint, mobile phone NFC

Card storage capacity: 100pcs

Fingerprint storage capacity: 300pcs

Control mode: 10 control modes

(Relay delay and waiting time can be adjusted)

# NFC-FP-S04

**KIT CONTROLE POUR TELEPHONE PORTABLE CONTROLE D'EMPREINTES DIGITALES CARTE  
IC MODULE RELAIS BRICOLAGE CONTROLE D ACCES CONTROLEUR DE CARTE COURTE.  
13.56MHZ**

**Note: Before using NFC, you need to turn on the NFC switch in the phone Settings. Android phones can be used only after you have created a blank card in the Wallet APP. For iPhone, you need to add any bus card or bank card into the "Wallet" APP of the phone. The bus card can be sensed only after it has been recharged.**

Blinking blue once: indicates relay mode 1

1)Fingerprint or card unlocked successfully, 3V interface output, wait for 1S, relay 1 connected 0.5S disconnect.

The fingerprint or card is unlocked successfully again.

2)The relay 2 is disconnected after 0.5 seconds of connection, and the 3V interface is powered off.

Blinking blue twice: indicates relay mode 2

1)If the fingerprint or card is unlocked successfully, relay 1 is connected; If the fingerprint or card fails to be unlocked again, relay 1 will be disconnected.

2)If the fingerprint or card is successfully unlocked again, relay 2 will also be connected. After releasing the finger or removing the card, relay 2 will power off immediately.

3)Verify the card or fingerprint again, and disconnect relay 1 regardless of success or failure.

Blinking blue three times: indicates relay mode 3

1)If the administrator fingerprint or management card is unlocked successfully, relay 1 is connected. After it is unlocked successfully again, relay 1 is disconnected.

2)If the fingerprint or user card of the common user is unlocked successfully, the relay 2 will be disconnected after 0.5 seconds of connection.

Blue light flashes four times: represents relay mode 4

1)After the administrator fingerprint or management card is unlocked successfully, relay 1 is connected, and after it is unlocked successfully again, relay 1 is disconnected.

2)After the user card is successfully unlocked, relay 2 will be disconnected after 0.5 seconds of connection.

3)After the user's fingerprint is used to unlock successfully, the optional relay 3 will be disconnected after 0.5 seconds of connection.

## **NFC-FP-S04**

### **KIT CONTROLE POUR TELEPHONE PORTABLE CONTROLE D'EMPREINTES DIGITALES CARTE IC MODULE RELAIS BRICOLAGE CONTROLE D ACCES CONTROLEUR DE CARTE COURTE. 13.56MHZ**

Blue light blinking five times: indicates relay mode 5:

1)If the administrator fingerprint or management card is unlocked successfully, relay 1 is connected. After it is unlocked successfully again, both relays 1 and 2 are disconnected.

2)After the common user card is unlocked successfully, relay 2 is connected. After it is unlocked successfully again, relay 2 is disconnected.

3)If fingerprint unlock is successful for common users, disconnect with relay 3 after 0.5 seconds connection.

Blue light blinks six times: indicates relay mode 6

1)If the fingerprint or card is unlocked successfully, relay 1 and 2 will be connected at the same time; Disconnect after 0.5 seconds.

The blue indicator blinks seven times: indicates relay mode 7

1)If the fingerprint or card is unlocked successfully, relay 1 and 2 are connected simultaneously; After unlocking again, relays 1 and 2 are disconnected simultaneously.

Blinking blue eight times: indicates relay mode 8

1)Fingerprint or card unlocked successfully, 3V interface output, wait for 1S, relay 1 connected 0.5S disconnect. (Relay 3 is switched on)

2)If fingerprint unlocking fails or the card is unlocked again, relay 2 will be disconnected after being connected for 0.5S, and 3V interface will be disconnected after 5s. (Relay 3 is disconnected)

Blue light blinking nine times: indicates relay mode 9

1)Management fingerprint or management card unlocked successfully, 3V interface output, wait for 1S, relay 1 connected 0.5S disconnected. (Relay 3 is switched on)

2)After the user fingerprint or user card is unlocked successfully, relay 2 will be disconnected after being connected for 0.5S, and the 3V interface will be disconnected after a delay of 5s. (Relay 3 is disconnected)

# NFC-FP-S04

KIT CONTROLE POUR TELEPHONE PORTABLE CONTROLE D'EMPREINTES DIGITALES CARTE  
IC MODULE RELAIS BRICOLAGE CONTROLE D ACCES CONTROLEUR DE CARTE COURTE.  
13.56MHZ

Blue light blinks ten times: indicates relay mode 10

1)Management fingerprint or management card unlocked successfully, 3V interface output, wait for 1S, relay 1 connected 0.5S disconnected.

2)The user card is unlocked successfully, and relay 2 is connected. Disconnect after 0.5S; The 3V port is powered off after 5s delay.

3)The user's fingerprint is unlocked successfully, and relay 3 is connected. Disconnect after 0.5S.

**Note: The packing list does not contain relay 3, please purchase according to individual needs. (Relays are not needed for refit electric bicycle and car door control 3)**

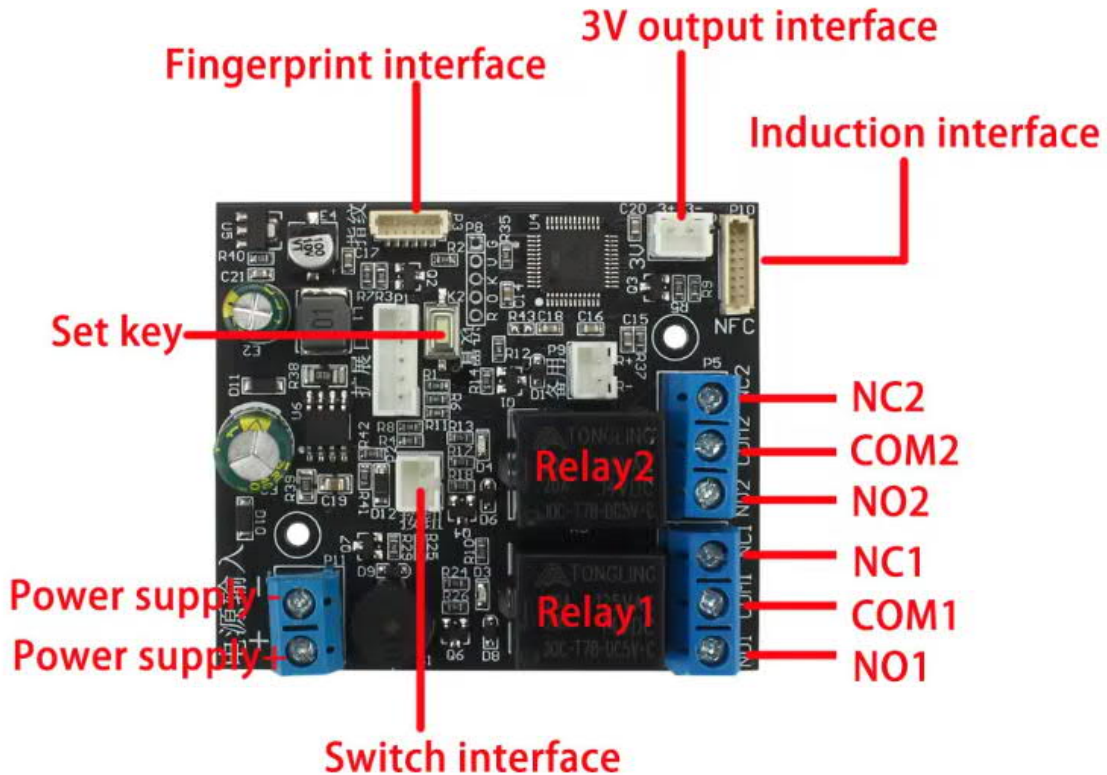

# NFC-FP-S04

KIT CONTROLE POUR TELEPHONE PORTABLE CONTROLE D'EMPREINTES DIGITALES CARTE  
IC MODULE RELAIS BRICOLAGE CONTROLE D ACCES CONTROLEUR DE CARTE COURTE.  
13.56MHZ



【Standard set and S4 fingerprint】  
Control board \*1, induction coil \*1, S4 fingerprint \*1

# NFC-FP-S04

KIT CONTROLE POUR TELEPHONE PORTABLE CONTROLE D'EMPREINTES DIGITALES CARTE  
 IC MODULE RELAIS BRICOLAGE CONTROLE D ACCES CONTROLEUR DE CARTE COURTE.  
 13.56MHZ

## Car door remote control modification scheme

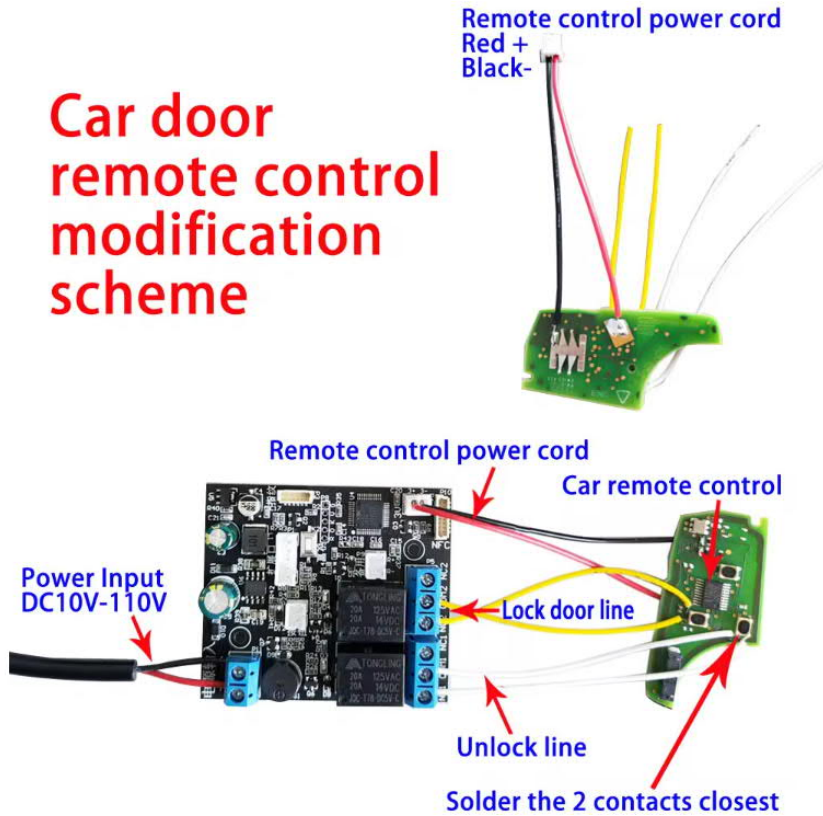

## Connect the car remote control to control the door modification scheme (Use 1/8/9 control mode)

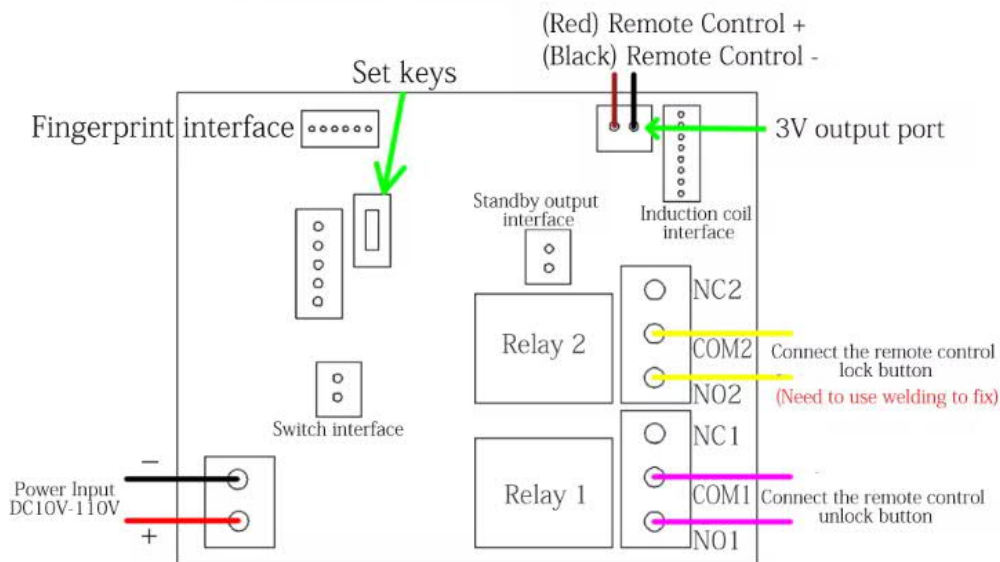

# NFC-FP-S04

KIT CONTROLE POUR TELEPHONE PORTABLE CONTROLE D'EMPREINTES DIGITALES CARTE  
IC MODULE RELAIS BRICOLAGE CONTROLE D ACCES CONTROLEUR DE CARTE COURTE.  
13.56MHZ

## Car central control button control door modification scheme (Use 1/8/9 control mode)

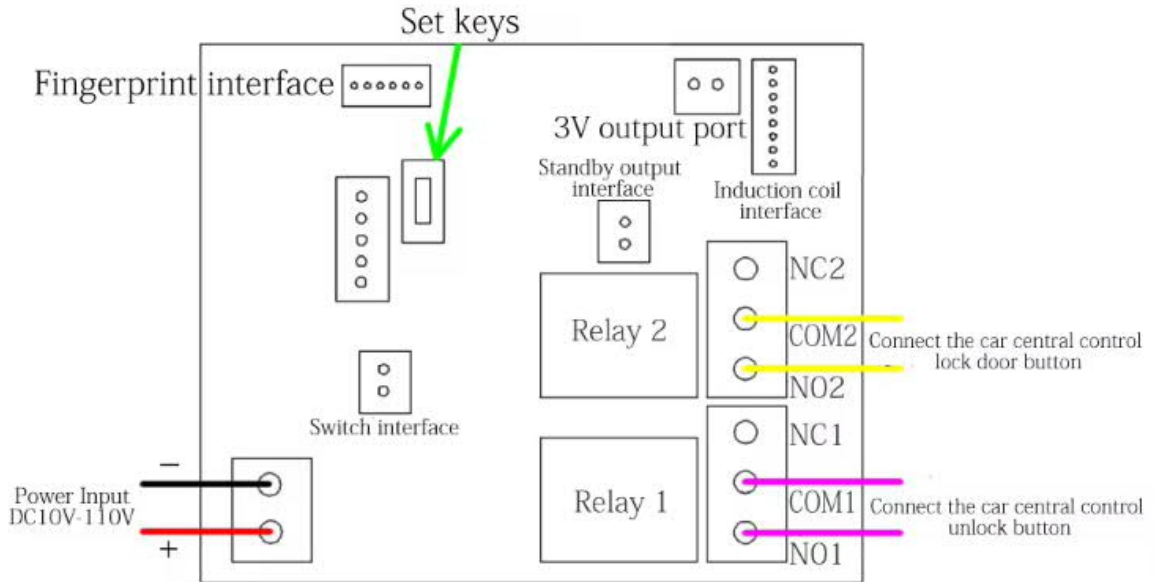

## Car one button start modification scheme (Use 2 control mode)

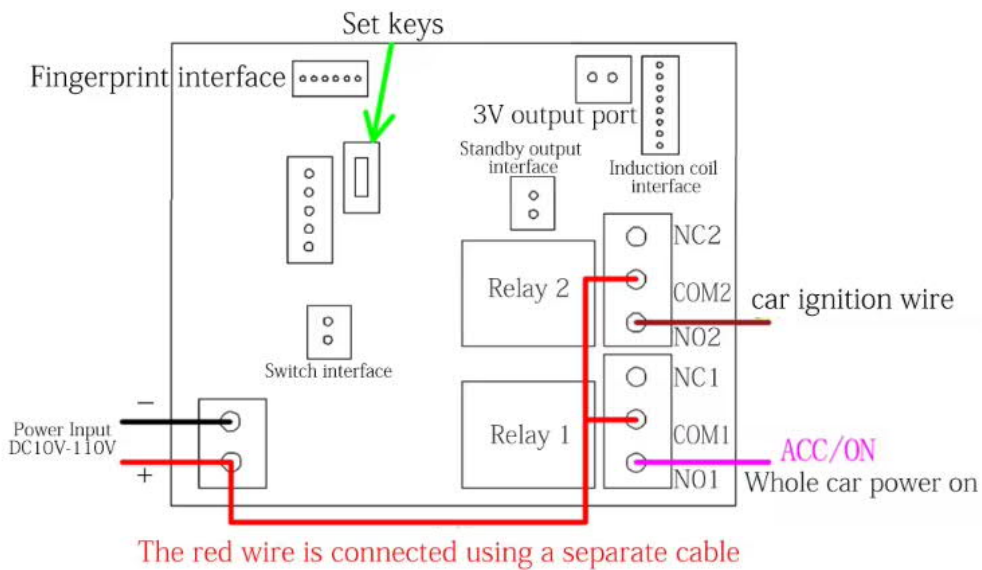

# NFC-FP-S04

KIT CONTROLE POUR TELEPHONE PORTABLE CONTROLE D'EMPREINTES DIGITALES CARTE  
IC MODULE RELAIS BRICOLAGE CONTROLE D ACCES CONTROLEUR DE CARTE COURTE.  
13.56MHZ

## Electric bicycle swipe card start modification scheme

If you only need to swipe the card to start the function, use Mode 7 control

If you need to enable function + control headlights, please use Mode 5 control

If you need to enable function + storage lock control, use Mode 3/4 control

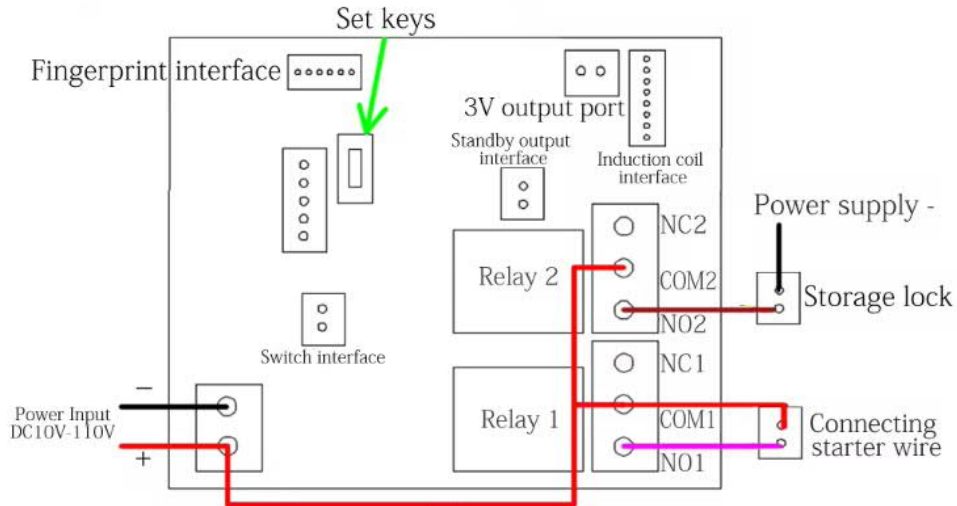

The red wire is connected using a separate cable

S4 Fingerprint module size (unit: mm)

